

# Home Range Ecology of an Introduced Population of the European Wall Lizard *Podarcis muralis* (Lacertilia; Lacertidae) in Cincinnati, Ohio

RAFE M. BROWN

*Department of Zoology, Miami University, Oxford, Ohio 45056*

DANIEL H. GIST

*Department of Biological Sciences, University of Cincinnati, Cincinnati, Ohio 45221*

AND

DOUGLAS H. TAYLOR

*Department of Zoology, Miami University, Oxford, Ohio 45056*

**ABSTRACT.**—A 2-yr field study of introduced wall lizards, *Podarcis muralis*, revealed a resident population which remained remarkably stable ( $n = 37$  lizards for each year). Slightly more than half of the 167 wall lizards originally captured and marked disappeared from the study sites and were classified as nonresidents. Males occupied significantly larger home ranges than females and, in 1991, had higher instances of intersexual home range overlap than did females. Instances of female-female home range overlaps in 1991 were more numerous than corresponding overlap between males. There was no difference between the sexes with respect to mean percentage of home range overlap in 1990, but females exhibited greater percent overlap in 1991. Small home range size and high home range overlap suggest that the Cincinnati population may have switched from territorial behavior (reported for European populations) to a hierarchical dominance system, possibly in response to unique pressures (high lizard densities, high predation pressures and low availability of preferred habitat) in the Cincinnati area. We interpret our results in light of recent findings regarding lizard spacing patterns, optimality theory and predictions concerning introduced lizard populations. We also compare our data on one of the only successfully introduced lacertid lizards in North America to data from native European populations.

## INTRODUCTION

Studies of lizard spacing patterns, home range ecology and territoriality have examined the effects of these phenomena on population regulation (Tinkle *et al.*, 1962; Boag, 1973; Tinkle, 1967; Philibosian, 1975), reproductive success (Blair, 1960; Rand, 1965; Tinkle, 1965, 1967; Ferguson *et al.*, 1966; Simon, 1975; Schoener, 1983, 1987; Ruby, 1978), access to limiting resources like food (Blair, 1960; Rand, 1965; Milestead, 1970; Simon, 1975; Krenkorian, 1976; Simon and Middendorf, 1980), and adult or offspring survival (Blair, 1960; Rand, 1965; Tinkle, 1967; Fox, 1978, 1983; Fox *et al.*, 1981; Simon and Middendorf, 1980; Ferguson *et al.*, 1983). Rand (1965) hypothesized that, in general, possession of a rigorously defended territory should lend a selective advantage to a male lizard but that the benefits of territorial behavior may not exist in "small populations in unusual habitats" or in "recently occupied areas" (Rand, 1965: 107). The question then arises: what may be expected if previously advantageous territorial traits become selectively neutral as in the case of Rand's theoretical, small, isolated population? Optimality theorists contend that if behavior, like morphology, is a balance between different selective forces (Ehrman and Parsons, 1976), the relative advantage of territorial behavior might be expected to change over time (Orians, 1961; Owen-Smith, 1977; Wittenburger, 1980; *see also* reviews in Carpenter, 1958,

1965; Rand, 1965; Stamps, 1977, 1983; Davies and Houston, 1984; Stamps and Eason, 1989) and the degree of territorial behavior actually displayed may change with varying selective pressures of a cost/benefit gambit (Davies and Houston, 1984; Krebs and McCleery, 1984). The advantages of territoriality for lizards include exclusive exploitation of food sources and access of mates (Rand, 1965; Carpenter, 1965; Simon, 1975; Simon and Middendorf, 1980; Schoener, 1983, 1987), familiarity with refuges from predators (Rand, 1965; Simon and Middendorf, 1980; Stamps, 1983), potential niche space availability for offspring (Brattstrom, 1974; Davies and Houston, 1984), and an overall decrease in intraspecific interference competition (*review* Kauffmann, 1983). The disadvantages of territorial behavioral include physiological costs in terms of energy expenditure (Rand, 1965; Simon, 1975; Ruby, 1978), a possible decrease in overwintering survival due to expenditure of fat reserves while patrolling and defending an area (Avery, 1970, 1974; Castilla and Bauwens, 1990; *see also* Claussen *et al.*, 1989), reduced survivorship from increased risks of injury and predation during the active season (for discussion of costs and benefits of territoriality and other related topics, *see* reviews in: Carpenter 1958, 1965, 1978; Rand, 1965; Brattstrom, 1974; Stamps, 1977, 1983; Ferguson *et al.*, 1983; Kaufmann, 1983; Davies and Houston, 1984). If the associated costs begin to outweigh the benefits of defense of a territory and its resources, optimality theory would predict a decrease in territoriality or a switch to hierarchical dominance relationships characteristic of a "pecking order" (Hunsaker and Burrage, 1969; Rand, 1965; Brattstrom, 1974; Stamps, 1977, 1983; Kaufmann, 1983; Davies and Houston, 1984; Krebs and McCleery, 1984). In many species that are territorial at naturally low densities, dominance hierarchies may form if conditions (experimental laboratory manipulations or obtrusive field enclosure studies) result in an increase in population density (Hunsaker and Burrage, 1969; Brattstrom, 1974). In such instances, crowding and intraspecific aggression become inflated and the benefits of territoriality no longer outweigh the associated costs (*see* reviews in Carpenter, 1965, 1978; Brattstrom, 1974; Stamps, 1977, 1983; Greenberg, 1978; Jenssen, 1978; Kaufmann, 1983; Davies and Houston, 1984). Moreover, behavior may vary in response to environmental heterogeneity and unpredictability (Simon, 1975; Kjekorian, 1976), a fact which prompted Ferguson *et al.* (1983) to suggest that the most fit individuals of *Sceloporus jarrovi* should be those who can modify their behavior to respond to fluctuations in food availability and other factors of the biotic environment (*see also* Simon, 1975; Ruby, 1978; Simon and Middendorf, 1980).

*History of Podarcis muralis in Cincinnati, Ohio.*—*Podarcis muralis* is a small oviparous, diurnal, old world lacertid lizard widely distributed throughout much of mainland Europe (Arnold and Burton, 1978). Following a vacation to Northern Italy (Lago di Milan and/or Lago di Como areas) by a Cincinnati resident in the early 1950s, several individuals of this species were released into a single yard on the eastern edge of the city (Vigle, 1977; Hedeén, 1984). Over the past 40 yr, this population has spread throughout much of the city's E side along S-facing hillsides bordering the Ohio river (Conant and Collins, 1991). The success of *P. muralis* in Cincinnati has been attributed to favorable habitat, a lack of interspecific competition, preadaptation in their original range, and similar seasonality in both northern Italy and Cincinnati (Hedeén, 1984). Described as a human "culture follower" (Gruschwitz and Bohme, 1986: 16), *P. muralis* is considered "more adventurous and opportunistic" than other closely related lacertids (Arnold and Burton, 1978: 193) and represents the most urban lacertid in Europe (Arnold and Burton, 1978; Gruschwitz and Bohme, 1986). Several years ago a census estimated lizard densities at 1500 individuals/acre in Cincinnati (Kwiat and Gist, 1987). In Cincinnati *P. muralis* now occurs in clumped distributions with numerous breeding colonies of densely congregated individuals centered around areas of preferred habitat (urban areas such as vacant lots, parks, private gardens and yards). Predom-

inant characteristics of such habitat include S-facing stone containment walls, equipment storage areas with rubbish heaps, building remains, garden walls and rocky hillsides. The frequent association of underbrush and cultivated bushes with the features of preferred habitat mentioned above is particularly important for the establishment and perseverance of wall lizard colonies in Cincinnati. *Podarcis muralis* may use an arboreal, vegetation-facilitated, predator-avoidance tactic in Cincinnati which allows for escape from avian and feline predators via retreat into underbrush where a large predator can not follow (Brown *et al.*, in press). These types of habitats and habitat characteristics are very similar to those of *P. muralis*' native range (Avery, 1978; Arnold and Burton, 1978; Gruschwitz and Bohme, 1986; Kwiat and Gist, 1987; Avery *et al.*, 1987; Conant and Collins, 1991; Damme *et al.*, 1992).

Despite belonging to a genus whose territorial behavior has been characterized as "poorly developed" (Carpenter, 1978), European *Podarcis muralis* has been shown to occupy overlapping, rigorously defended, mutually exclusive territories, with especially high levels of intraspecific aggression recorded, particularly during the breeding season (Steward, 1965; Boag, 1973; Avery, 1978, 1980; Gruschwitz and Bohme, 1986). Rand's assertion (1965) that territoriality may not be favored in situations involving small numbers of recent colonists occupying unusual habitat provoked our interest in the Cincinnati population which is a relatively small population in a recently invaded area.

Here we report on several aspects of the home range ecology of one of the only two successfully introduced lacertids in North America, the other being *Podarcis sicula* (Conant and Collins, 1991). We also compared our data with those reported for European populations of this species in order to determine if wall lizard behavior and spacing patterns in Cincinnati have shifted during the past 40 yr of isolation.

#### MATERIALS AND METHODS

We selected two field sites (0.9 km apart) on fenced private property that guaranteed minimal disturbance, supported colonies of wall lizards and also contained suitable habitat characteristics for lizard populations (rock and wood piles, low walls, railroad ties, scrap metal and other debris). Site 1 was 576 m<sup>2</sup> and Site 2 was 129 m<sup>2</sup>. Selection of field sites maximized horizontal surfaces, the prevalence of which is an assumption central to home range measurement via the convex polygon technique (Rose, 1982), and also to the density index used by us (Heckel and Roughgarden, 1979). When a vertical surface area could not be avoided, it and its inhabitants were excluded from home range estimates and related analyses. Field work was conducted from 3 June to 26 August 1990 and from 7 June to 26 August 1991. The two study sites were divided into grid systems of 2 × 2 m<sup>2</sup> with aluminum stakes and numbered flags, after carrying out an exhaustive effort to capture all lizards in each site at the beginning of each summer. Wall lizards were captured with a 2.0-m fishing pole fitted with a retractable noose on the tip. Sex, snout-to-vent length (SVL), tail length, and mass were recorded to the nearest 0.1 mm or 0.1 g, respectively. Because excessive handling has been shown to influence lizard behavior (Rodda *et al.*, 1988), we chose a method of identification which minimized daily disturbance of individual lizards. Identification was permanently insured by toe-clipping and less permanently (1–2 mo) by painting numbers on the lizards' sides. Identification numbers were visible to a nonobtrusive observer at a distance (15–30 m) with the aid of 7 × 35 binoculars. Study sites were each visited a minimum of four times per week during summer months and the locations of all lizards were recorded to the nearest 0.5 m by assigning every capture or resighting occurrence a quadrant number and an additional estimated value between 1 and 16 that described the horizontal position of the animal in the quadrant. Density estimates were made by direct counts of lizards on each study site and also through the use of a mark-resighting

TABLE 1.—Numbers and percentages of all wall lizards (residents with home ranges and nonresidents for which no home range calculations were made) sampled for 1990 and 1991. Data are for both sites combined

Sex	Resident	Nonresident	Total per sex	F/M ratio	Percentage of total
1990					
Male	16	14	30	—	35.3
Female	21	34	55	—	64.7
Total	37	48	85	1.83	100
1991					
Male	17	14	31	—	37.8
Female	20	31	51	—	62.2
Total	37	45	82*	1.64	100

\* n = 167 for both years combined; 21 of the original 37 wall lizards from 1990 survived as residents in 1991

index (Heckel and Roughgarden, 1979); for the sake of comparisons, lizard biomass is expressed herein on a per hectare and per acre basis.

To minimize the effects of the observer, only the first sighting of an individual on a given day was included in home range calculations. Individual home ranges were quantified by connecting the outermost points (sightings or recaptures) on a map drawn to scale on graph paper for each site and converting the area of the resulting minimum convex polygon (measured with a planimeter) into horizontal home range size (*see* Rose, 1982, for discussion of this method). To quantify the density and sex-specific trends in the structure of home range polygon clusters, we recorded the number of adjacent, overlapping polygons in contact with each lizard's home range. Home range percent overlap was defined as the percentage of an individual's home range that was shared with that of an adjacent resident lizard (Ferner, 1974). In an effort to include both the social dominants (frequently sighted owners of conspicuous perches) and more reclusive subordinates (less frequently observed, often amongst vegetation or other concealing refuges), lizards were considered residents if they were sighted  $\geq 4$  times inside a site's boundaries per given month for the 3 consecutive-month field season. We also investigated the relationship between number of sightings and home range size estimation by plotting the cumulative home range size ( $m^2$ ) against number of observations for each animal (after Tinkle, 1967). The combined data, converted into the percentage of final maximum home range area and plotted against the number of observations, were used to indicate the minimum number of sightings/recaptures required to confidently estimate the actual home range (at the point of the curve's asymptotic maximum). Statistical analyses [Analyses of Variance (ANOVAs) and Repeated Measures ANOVAs] were carried out using Statistical Analysis Software version 6.03 (SAS Institute, Inc., 1988a, b) after checking data for assumptions of normality (Sokal and Rohlf, 1981).

## RESULTS

Records for 167 permanently marked wall lizards indicate that numbers remained remarkably stable over the 2 field seasons (Table 1). Forty-six percent of the permanently marked males and 53.5% of the marked females in 1990 were sighted on fewer than 4 days in a given month or were not present for 3 consecutive mo; these individuals were classified as nonresidents. Similarly, 45% of the males and 61% of the females marked in 1991 were

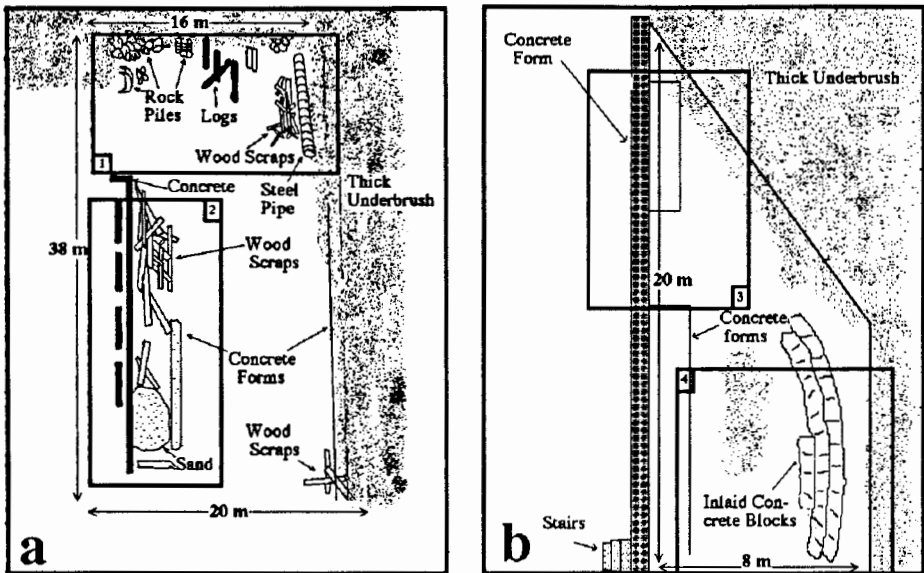

FIG. 1.—Schematic representations of sites 1 (a) and 2 (b). The heavily bordered black boxes in site 1 encompass areas 1 and 2 which are shown in more detail in Figure 2 (a, b, and c); the same boxes which encompass area 3 and 4 in site 2 are shown in greater detail in Figure 3 (a–c). Note the orientation of home range polygon clusters surrounding areas which include sufficient debris for lizard refuges and basking sites

categorized as nonresidents in the manner described above. During both years, nonresident lizards were usually sighted once, or occasionally twice at a considerable distance from the first sighting, but never three times and never again after the initial loss of contact.

The remaining marked wall lizards were all considered residents (*see below*). When the number of sightings was plotted against the cumulative percentage of the maximum home range size (after Rose, 1982), the asymptote of the resulting curve indicated that the majority of Cincinnati wall lizard home ranges could be estimated from 12–15 sightings/recaptures; wall lizards for which there were 14 or fewer sighting/recapture records were excluded from subsequent home range size calculations. Nonresident lizards generally traveled in straight lines through the study sites (Fig. 1). The movements of resident lizards, in contrast, were localized, repetitive and restricted to a well defined home range.

Lizard density was almost twice as high at site 2 as at site 1 (Table 2). The density index used estimated lizard numbers to be a third again as high as density calculated from direct counts. Home ranges of wall lizards show a high degree of overlap (Figs. 2 and 3).

TABLE 2.—Density (expressed as numbers of lizards per hectare and acre) calculations by direct counts and mark-recapture indexes (Heckel and Roughgarden, 1979). Data are for 1990 only

Site	Direct counts	Index
1	451/ha (1114/ac)	690/ha (1700/ac)
2	852/ha (2105/ac)	1250/ha (3100/ac)

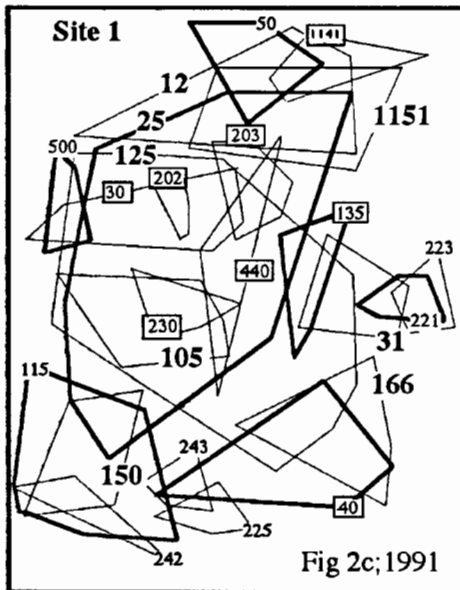
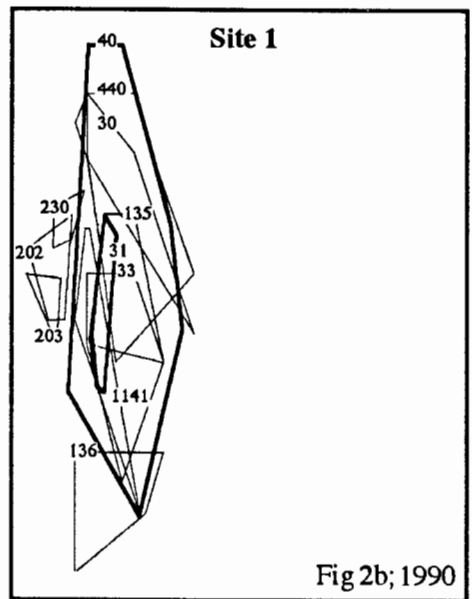
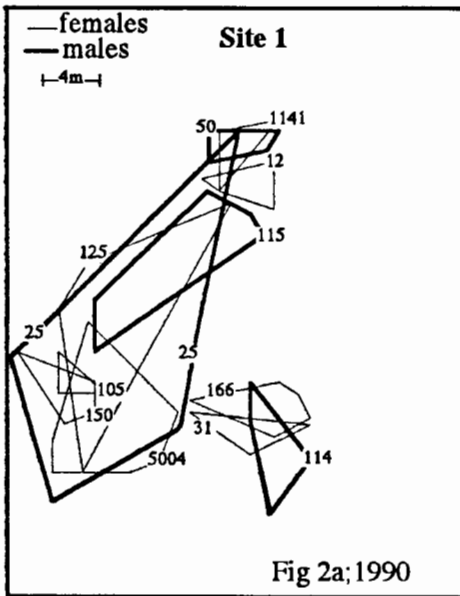

FIG. 2.—Home range polygon clusters for site 1 from Figure 1a. Figures 2a and 2b show detail from Figure 1a, area 1 and 2, respectively, for 1990 home ranges. In 1991, the lizards from 2b were disturbed and became incorporated into the resulting home range polygon cluster shown in 2c (Fig. 1a, area 1). In 2c, larger numbers indicate surviving lizards from 1990 and boxed numbers indicate individuals which invaded the area following the disturbance at 2b (Fig. 1a, area 2)

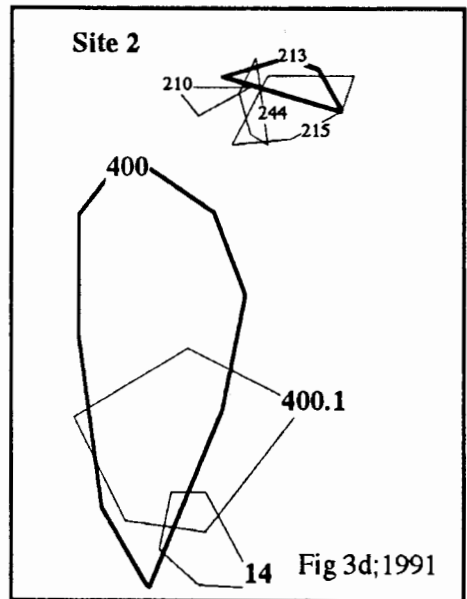
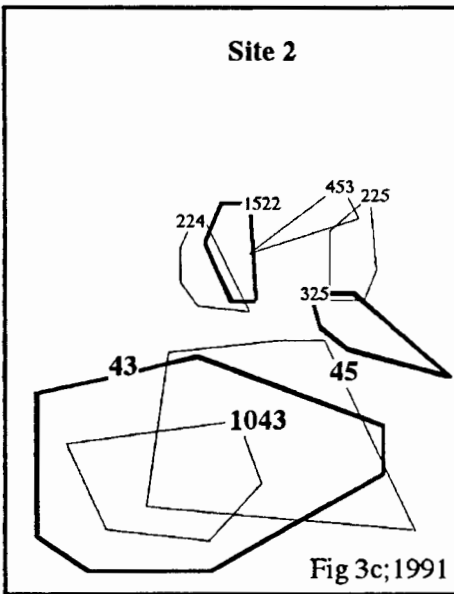
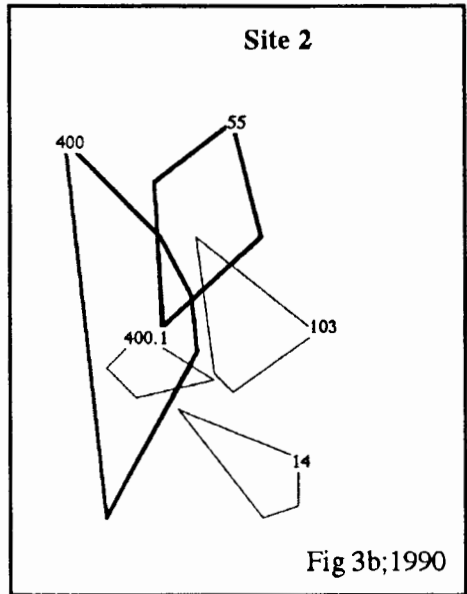
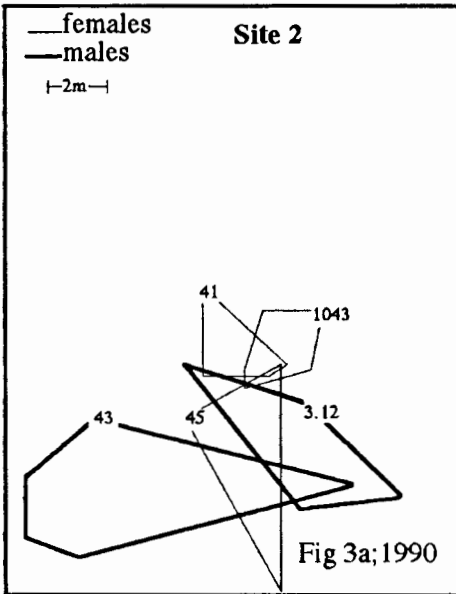

FIG. 3.—Home range polygon clusters for site 2 from Fig 1b. Figures 3a and 3b show detail from Figure 1b, areas 3 and 4 for 1990 home ranges; 3c and 3d show the same areas in 1991 (large bold numbers indicate survivors). Note the lower density of lizards relative to site 1 and the appearance of YOY cohort juveniles invading the upper side of both polygon clusters in 3c and 3d

Comparisons of home range polygon cluster diagrams from 1991 with those of 1990 reveal the presence of both survivors and younger age class individuals in the 1991 population. Several of these newly established residents apparently entered the field sites in 1990 as the young-of-the-year (YOY) recruitment cohort (=yearlings during the 1991 breeding season) and replaced non-surviving resident lizards between the 1990 and 1991 field seasons (compare Fig. 3a and 3b with 3c and 3d).

When we analyzed the home range size data for the 37 resident lizards in 1990 (Fig. 4a), a two-factor ANOVA showed no significant difference between sites ( $df = 1, 33; F = 0.03; P > 0.05$ ), a marginally greater mean male home range size ( $df = 1, 33; F = 3.74; P = 0.059$ ) and no significant interaction between the sources of variation ( $df = 1, 33; F = 0.64; P > 0.05$ ). The effect of sex on home range size became slightly more pronounced in 1991 ( $n = 37; df = 1, 33; F = 5.52; P = 0.025$ ) but site and interaction effects were still statistically insignificant ( $P$ 's  $> 0.05$ ; see Fig. 4a). Figure 4b shows consistent annual increases in mean ( $\pm 1$  SE) home range for 21 lizards which survived as residents through both of the 1990 and 1991 field seasons. Home range size increased significantly between 1990 and 1991 (Repeated Measures ANOVA:  $df = 1, 17; F = 18.6; P = 0.005$ ) and surviving resident males had larger home ranges than surviving resident females ( $df = 1, 17; F = 4.8; P = 0.04$ ) but no site or interaction effects were detected ( $P$ 's  $> 0.05$ ).

Males' home ranges overlapped with each other less often than females' home ranges overlapped (note intrasexual comparisons: site 1 males and site 2 females; Fig. 5b). In addition, males home ranges overlapped female's home ranges more often than females home ranges intersexually overlapped males' home ranges (note site 1 males vs site 2 females; Fig. 5a). While differences between male and female home range overlap were not significant in 1990 (Two Factor ANOVA:  $df = 1, 17; F = 2.1; P > 0.05$ ), they became more pronounced in 1991 ( $df = 1, 36; F = 11.8; P = 0.002$ ), as did differences between the sites (1990:  $df = 1, 17; F = 3.9; P = 0.055$ ; 1991:  $df = 1, 36; F = 5.0; P = 0.039$ ). No interaction effects were detected either year ( $P > 0.05$ ). Within-sex differences between male and female home range overlap were not significant in 1990 (Two Factor ANOVA:  $df = 1, 17; F = 3.1; P = 0.09$ ), but were in 1991 ( $df = 1, 36; F = 5.9; P = 0.02$ ). The site effect and interaction term were not statistically significant in intrasexual comparisons ( $P > 0.05$ ).

Mean intrasexual home range percentage overlap was higher in site 1 than in site 2 during both years (Fig. 6), but only in 1990 was there a statistically significant main site effect (Two Factor ANOVA, 1990:  $df = 1, 41; F = 5.7; P = 0.02$ ; 1991:  $df = 1, 60; F = 0.45; P > 0.05$ ). Conversely, sex had no significant effect in 1990 ( $df = 1, 41; F = 1.8; P > 0.05$ ) but females exhibited significantly greater mean percentage overlap in 1991 ( $df = 1, 60; F = 4.1; P = 0.04$ ). No significant interaction terms were detected between site and sex for home range percentage overlap data ( $P > 0.05$ ).

One aggregation of wall lizards in Site 1 (Fig. 1a, area #2) was disturbed on 11 July 1991 when debris piles used as basking sites and refuges by resident lizards were removed by property owners. For the next several days following the disturbance, resident wall lizards were observed traveling beyond the boundaries of previously established home ranges and often left the site or interacted with other nearby individuals with whom their home ranges had not previously overlapped. The long-term results of this habitat disturbance varied: two female lizards (#s 130 and 33) were observed being taken by feral cats when their retreats were no longer available; a single female resident (#136) disappeared from the study area and was presumed to have been taken by a feline predator as well. The remainder of the resident lizards ( $n = 8$ ) from this area became incorporated into the region shown in Figure 1a, area #1, following several days of intense agonistic interactions (postural displays, charges, stereotyped "pawing" front foot movements, and even biting and prolonged fighting)

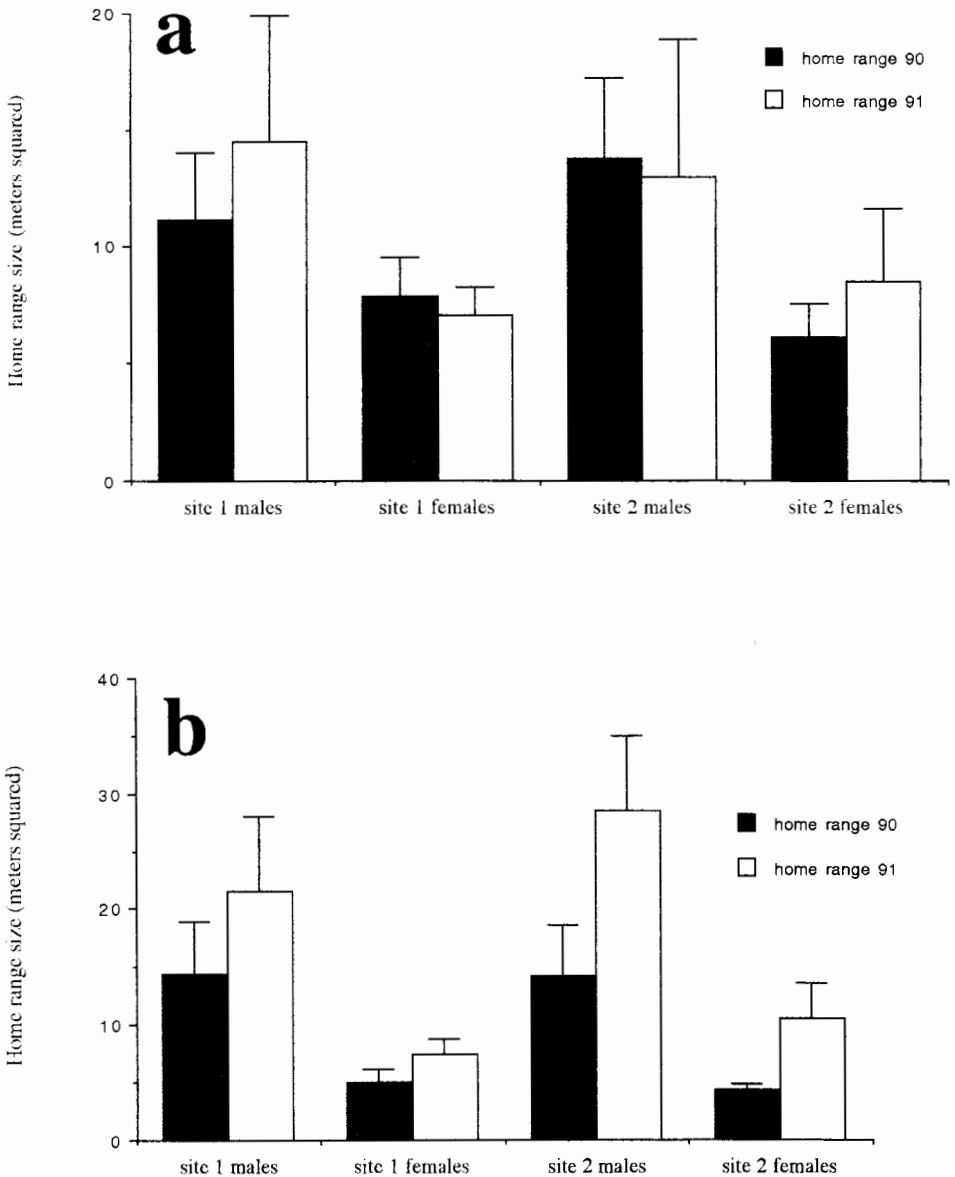

FIG. 4.—Mean home range size ( $m^2$ ) for all resident wall lizards (a;  $n = 37$  for both years) and separately treated 2-yr survivors (b;  $n = 21$ ). Vertical error bars indicate 1 SE of the mean. See text for discussion of statistical significance.

with the residents in area #1. The resulting home range polygon cluster (Fig. 2c) for 1991 shows a rearrangement from 1990 reflecting the incorporation of (1) newly established resident lizards which came into the colony and replaced nonsurviving 1990 residents; (2) the establishment of invading new residents from the area #2 in 1990 into the new 1991

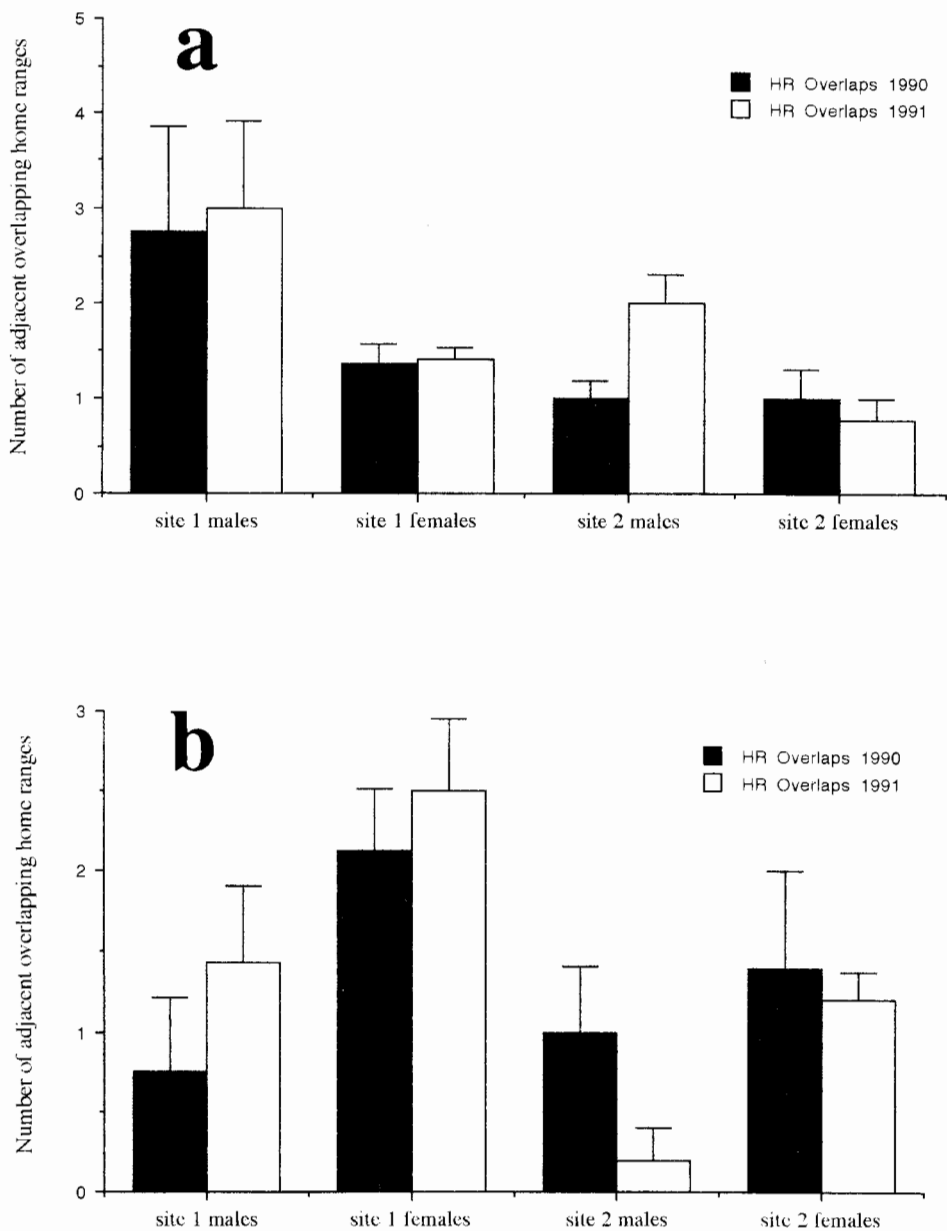

FIG. 5.—Mean number of neighboring (connecting) home range polygons which overlap into each individual's home range. Data were computed both inter- (a) and intrasexually (b) and error bars indicate 1 SE of the mean. See text for discussion of statistical significance.

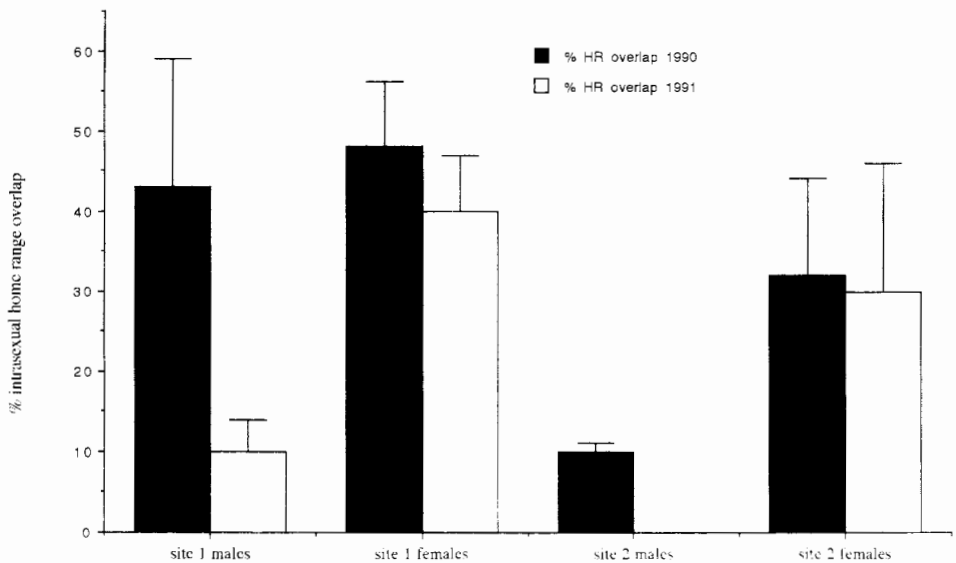

FIG. 6.—Home range overlap percentage data for wall lizards of both sexes at each site during 1990 and 1991. Note the decrease in percent overlap at site 1 in 1991 and the complete absence of male-male overlap at site 2 during the same year. Vertical error bars indicate 1 SE of the mean. See text for discussion of statistical significance.

area #1, and (3), the presence of surviving area #1 1990 residents still in the same region of the study site in 1991.

#### DISCUSSION

Wall lizard density at site 2 was estimated to be twice that at site 1 where a more accurate estimate of density is presumed to have been achieved. At site 1, lizard density was very near that estimated in 1985 (Kwiat and Gist, 1987). Differences between direct counts and the density index (Table 2) appear to indicate disparities between ecological and crude densities. Dixel (1984) reported a density of 100 animals per hectare in native Italian populations of wall lizards. This number is far below our estimates from the Cincinnati population (Table 2) and strengthens our contention that the Cincinnati population is characterized by extremely dense aggregations of lizards centered around suitable habitat.

At site 1 where density (direct counts, see Fig. 2) was high and preferred habitat availability decreased during this study, wall lizards occupied home ranges in dense aggregates that indicate hierarchical social systems (Hunsaker and Burrage, 1969; Ferner, 1974; Brattstrom, 1974; Krekorian, 1976). Wall lizards in Cincinnati are not evenly distributed throughout their range, but occur in isolated pockets at extremely high densities around debris piles and rock walls on the city's E side (RMB, pers. observ.). The degree of social pressure and competition for the available space at locations of suitable habitat has not been clearly ascertained, but the following lines of evidence recorded by us suggest that competition for space in the Cincinnati population may indeed be very strong. More than half of the lizards which were captured and marked in this study were categorized as nonresident "floaters" (Rose, 1982). Nonresident males traveling through the study site were often seen copulating with resident females ( $n = 16$  observed copulations of this type), were often aggressively

supplanted by residents ( $n = 53$  observed resident-initiated agonistic interactions with non-residents), and often incorporated themselves into available space when residents succumbed to predation (compare 1990 home range diagrams with those from 1991; Figs. 2 and 3). It is unclear whether nonresidents are actually in a "constant state of mobility . . . in search of habitat" (Boag, 1973: 3) or are using an alternative strategy for the acquisition of mating opportunities. Incorporation of nonresidents into unoccupied habitat following the death of residents generally supports the former. Boag (1973), Dixel (1984) and Strijbosch *et al.* (1980) have all reported high degrees of mobility in nonresident *Podarcis muralis* in Europe (*see also* Avery *et al.*, 1987). Boag's (1973) assertion that a large portion of the population may become transient due to habitat shortages has been accepted by Gruschwitz and Bohme (1986). Conversely, if nonresident wall lizards are engaging in an alternative method of mate acquisition, this mechanism could be important in gene flow and help minimize inbreeding in small isolated colonies.

The presence of feral cats on the study sites was nearly constant throughout this study and while we only observed 24 kills (20 of which were the deaths of nonresidents), the instances of cats chasing lizards on our study sites were too numerous to count. Strong predation pressures may contribute to competition for optimal habitat with safe refuges from predators (Tinkle *et al.*, 1962; Tinkle, 1967; Fox *et al.*, 1981). As mentioned before, when safe refuges were taken away from resident lizards, several individuals were observed being stalked and killed by local cats.

*Podarcis muralis* home range size in Cincinnati varied from ca. 10–15 m<sup>2</sup> in males and from 5–10 m<sup>2</sup> in females with no significant differences between the sexes (Fig. 4). In contrast, *P. muralis* home ranges fluctuate between 15 and 25 m<sup>2</sup> in the Netherlands (also with no sex effect; Strijbosch *et al.*, 1980). Weber (1957) reported 15 m<sup>2</sup> as the average home range size in Swiss populations of *P. muralis* on crowded rock walls much like those in Cincinnati. Boag (1973) worked with Italian populations of *P. muralis* which were closer to the source of Cincinnati wall lizards. His data indicated mean home range sizes of 26 and 23 m<sup>2</sup> for males and females, respectively. All of these findings regarding European populations of *P. muralis* suggest that the Cincinnati environment has contributed to the reduction in home range sizes in the introduced population as compared with native populations.

These observations are consistent with the assertion that competition for space and predation pressures discouraging dispersal have brought about a hierarchical social system in the Cincinnati population. One lizard ecologist has noted: "If dispersal is impossible, then territory size per individual generally decreases until the social system switches to a hierarchical system" (Brattstrom, 1974: 38). It seems likely that predation pressures in Cincinnati have forced the same kind of switch to hierarchical behavior that can be brought about in laboratory settings by making dispersal an impossibility. While dispersal is certainly not impossible in a situation of high predation pressure, extensive activity patterns and movement away from safe, familiar refuges should not be selectively favored if such behaviors increase the chances of injury and death and lowers chances of producing viable offspring in the future. This fact may also account for small home range size and localized activity of individuals in Cincinnati populations of *Podarcis muralis*.

Numbers of home range overlaps per individual were very high in the Cincinnati population, indicating a possible social consequence of crowding and high lizard densities at pockets of preferred habitat. Similarly, the high degree of home range percent overlap in site 1 demonstrates that territory does not necessarily equal home range in this population (*see* Ferner, 1974). Milestead (1970) reported greater home range overlap in areas of high population density than in areas of low density in *Sceloporus merriami*, and Krekorian (1976)

has shown a presumably temporary switch to hierarchical behavior in the otherwise territorial *Dipsosaurus dorsalis* following catastrophic declines in food availability. Ferner (1974) interpreted a high degree of overlap as suggestive of a hierarchical social system and a promiscuous mating system in *Sceloporus undulatus*. The same may be true in Cincinnati wall lizards where home range structure is characterized by small size and a high degree of overlap (vs. European populations; see below; Boag, 1973). If competition for space occurs frequently in this population and intense crowding rules out the possibility of effectively driving conspecifics out of an individual's home range, male wall lizards may maximize reproductive success by attempting to include several potential mates into their home range rather than guarding one female enclosed within a territory (contrast with Fig. 1 of Tinkle *et al.*, 1962; see also Stamps, 1983). Data gathered on numbers of male home range intersexual overlaps support this possibility.

Females' home ranges overlapped with each other more often than did those of males, indicating a tolerance of same-sex conspecifics in females. This phenomenon may also be partly a consequence of a slightly biased sex ratio in this population (Table 1). Conversely, males tolerated fewer same-sex overlaps (Fig. 5b) and a lower degree of such overlap (Fig. 6). This may be due to attempts to limit the access of other males to females within an individual male's home range and to guard potential mates from same sex conspecifics via agonistic aggression. This tendency to exploit mating resources may also be expressed to a lesser degree in a hierarchical system according to the cost-benefit ratio of resource value vs. energy expenditure guarding it (Brattstrom, 1974; Kaufmann, 1983; Davies and Houston, 1984; Krebs and McCleery, 1984). Male home ranges overlapped females' home ranges more often than female home ranges overlapped males'. This indicates that males may be responsible for the overlap between the sexes, possibly as an adaptive strategy to acquire as many potential mates as possible and maximize reproductive fitness (Krebs and McCleery, 1984). The entire social and home range structure recorded here markedly contrasts with that of a territorial species which exhibits exclusive occupation of rarely overlapping territories and a high degree of association between the territories of single males and one or two females (Tinkle *et al.*, 1962; Tinkle, 1967).

Boag (1973) reported 8% (male) to 18% (female) home range overlap in Italian populations of *Podarcis muralis*, which is considerably lower than our values for the introduced Cincinnati population (Fig. 6). However, Strijbosch *et al.* (1980) interpreted an average of 60% overlap in Netherlands wall lizards to be a consequence of crowding in response to reduced optimal habitat. The same circumstance may be responsible for the Cincinnati population where choice habitat has been, and continues to be, reduced due to human activities. Much like Strijbosch *et al.* (1980), our highest values for percent home range overlap approached 60% (Fig. 6).

Established residents that survived both field seasons ( $n = 21$ ) demonstrated a capacity for home range expansion with age (Fig. 4b) which may indicate elevated hierarchical rank and increasing dominance with age (Carpenter, 1965; Brattstrom, 1974; Stamps, 1983) and also may be related to body size and energy requirements (Ruby, 1978; Brattstrom, 1974; Simon and Middendorf, 1980).

The disturbance of site 1 (area #2) lizard home ranges in 1991 provided an opportunity to observe what may be a frequent occurrence in this population, namely the destruction of prime habitat by the activities of humans and the dislodging of resident lizards which must then cope with finding a new area of residence or fall prey to omnipresent neighborhood cats. Interviews with local property owners in Cincinnati confirmed our suspicions to the effect that the widespread replacing of faulty or collapsing S-facing containment walls with smooth concrete or mortared stones has resulted in noticeable declines in lizard num-

bers after disturbance to the habitat. Such activities have contributed to the declines of populations of this species in certain parts of its native range (Gruschwitz and Bohme, 1986). The decimation of entire colonies of wall lizards by development in some areas of Cincinnati is not an uncommon phenomenon (DHG, pers. observ.). If wall lizards burrow back into hillsides behind S-facing walls for egg-laying and/or hibernation (*see* Bauwens, 1981 and Claussen *et al.*, 1989), then these improvement efforts on the part of local property owners may deny wall lizards access to brooding sites and hibernacula and, thus, contribute to their decline.

*Acknowledgments.*—We thank Jeff Burt, Cathy Guthrie, Eva Phenix and Earl Phenix for field assistance. The management and staff of Kelly Construction Company and H. C. Nutting Engineering Company graciously provided access to their private property for use as study sites. Dennis Claussen, Mike Finkler, John Ferner, Nancy Solomon and Tim Rice critically reviewed earlier drafts of the manuscript. This study was supported by the Student Field Research Fund of the Department of Biology, Reed College, and by an Explorers' Club Youth Activity Fund Grant to RMB. We thank Robert Shaeffer for statistical advice. RMB thanks Brian Bock and Scott Moody for advice and encouragement during initial stages of this project.

#### LITERATURE CITED

- ARNOLD, E. N. AND J. A. BURTON. 1978. A field guide to the reptiles and amphibians of Britain and Europe. Collins, London. 198 p.
- AVFRY, R. A. 1970. Utilization of caudal fat by hibernating common lizards, *Lacerta vivipara*. *Comp. Biochem. Phys.*, **37**:119–121.
- . 1974. Storage lipids in the lizard *Lacerta vivipara*: a quantitative study. *J. Zool. Proc. Zool. Soc. Lond.*, **173**:419–425.
- . 1978. Activity patterns, thermoregulation and food consumption in two sympatric lizard species (*Podarcis muralis* and *P. sicula*) from central Italy. *J. Anim. Ecol.*, **47**:143–158.
- . 1980. Ecophysiology and behavior of lacertid lizards—towards a syntopic model, p. 71–73. *Proc. Euro. Herp. Symp. C.W.L.P.*, Oxford.
- , C. F. MULLER, S. M. JONES AND D. J. BOND. 1987. Speeds and movements of European Lacertid lizards: a comparative study. *J. Herpetol.*, **21**:324–329.
- BAUWENS, D. 1981. Survivorship during hibernation in the European common lizard, *Lacerta vivipara*. *Copeia*, **1981**:741–744.
- BLAIR, W. F. 1960. The rusty lizard: a population study. Univ. Texas Press, Austin. 187 p.
- BOAG, D. A. 1973. Spatial relations among members of a population of wall lizards. *Oecologia (Berl.)*, **12**:1–13.
- BRATTSTROM, B. H. 1974. The evolution of reptilian social behavior. *Am. Zool.*, **14**:35–49.
- BROWN, R. M., D. H. TAYLOR AND D. H. GIST. 1995. Effect of caudal autotomy on locomotor performance of wall lizards (*Podarcis muralis*) in Cincinnati, Ohio. *J. Herpetol.*, **29**:98–105.
- CARPENTER, C. C. 1958. Territoriality: a review of concepts and problems, p. 224–250. *In*: A. Roc and C. C. Simpson (eds.), Behavior and evolution. Yale Univ. Press, New Haven, Conn.
- . 1965. Aggression and social structure in iguanid lizards, p. 87–106. *In*: W. W. Milestead (ed.), Lizard ecology: a symposium. Univ. Missouri Press, Kansas City.
- . 1978. Ritualistic social behaviors in lizards, p. 253–267. *In*: N. Greenburg and P. D. MacLean (eds.), Behavior and neurology of lizards. NIMH, Rockville, Md.
- CASHILLA, A. M. AND D. BAUWENS. 1990. Reproductive and fat body cycles of the lizard *Lacerta lepida*, in central Spain. *J. Herpetol.*, **24**:261–266.
- CLAUSSEN, D. L., M. D. TOOWNSLEY AND R. G. BAUSCH. 1989. Supercooling and freezing tolerance in the European wall lizard, *Podarcis muralis*. *Am. Zool.*, **29**:267–272.
- CONANT, R. AND J. T. COLLINS. 1991. Reptiles and amphibians of eastern and central North America. Peterson Field Guide Series, 3rd ed. Houghton Mifflin Company, Boston. 451 p.
- DAMME, R. VAN, D. BAUWENS, F. BRANA AND R. F. VERHEYEN. 1992. Incubation temperature differentially

- affects hatching time, egg survival, and hatchling performance in the lizard *Podarcis muralis*. *Herpetologica*, **48**:220-228.
- DAVIES, N. B. AND A. I. HOUSTON. 1984. Territory economics, p. 148-169. In: J. R. Krebs and N. B. Davies (eds.). *Behavioral ecology: an evolutionary approach*. Blackwell Scientific Publications, London.
- DEXEL, R. 1984. Zur ökologie der *Podarcis muralis* (Laurenti, 1768) (Sauria: Lacertidae) an ihrer nördlichen Arealgrenze. II. Populationsstruktur und -dynamik. *Salamandra*, **22**:259-271.
- EHRMAN, L. AND P. A. PARSONS. 1976. The genetics of behavior. Sinauer Associates, Sunderland, Mass. 390 p.
- FERNER, J. W. 1974. Home range size and overlap in *Sceloporus undulatus erythrocheilus* (Reptilia: Iguanidae). *Copeia*, **1974**:332-337.
- FERGUSON, G. W. 1966. Releasers of courtship and territorial behavior in the side-blotched lizard *Uta stansburiana*. *Anim. Behav.*, **14**:89-92.
- , J. L. HUGHES AND K. L. BROWN. 1983. Food availability and territorial establishment of juvenile *Sceloporus undulatus*, p. 135-148. In: R. Huey, D. Pianka and T. W. Schoener (eds.). *Lizard ecology*. Harvard Univ. Press, Cambridge, Mass.
- FOX, S. F. 1978. Natural selection on behavioral phenotypes of the lizard *Uta stansburiana*. *Ecology*, **59**:834-847.
- . 1983. Fitness, home range quality, and aggression in *Uta stansburiana*, p. 149-168. In: R. Huey, D. Pianka and T. W. Schoener (eds.). *Lizard ecology*. Harvard Univ. Press, Cambridge, Mass.
- , E. ROSE AND R. MYERS. 1981. Dominance and the acquisition of superior home ranges in the lizard *Uta stansburiana*. *Ecology*, **62**:888-893.
- GREENBERG, N. 1978. Ethological considerations in the experimental study of lizard behavior, p. 203-226. In: Greenberg, and P. D. McLean. (eds.). *Behavior and neurology of lizards*. NIMH, Rockville, Md.
- GRUSCHWITZ, M. AND W. BOHME. 1986 *Podarcis muralis* (Laurenti, 1768)—Mauereidechse, p. 155-208. In: W. Bohme (ed.). *Handbuch der reptilien und amphibien Europas*. Band 2/II. AULA-Verlag, Wiesbaden.
- HECKEL, D. G. AND S. ROUGHGARDEN. 1979. A technique for estimating the size of lizard populations. *Ecology*, **60**:966-975.
- HEDFEN, S. E. 1984. The establishment of *Podarcis muralis* in Cincinnati, Ohio. *Herpetol. Rev.* **15**:70-71.
- HUNSAKER, D. AND B. R. BURRAGE. 1969. The significance of interspecific social dominance in iguanid lizards. *Am. Midl. Nat.*, **81**:500-511.
- JENSSEN, T. A. 1978. Display diversity in Anoline lizards and the problems of interpretation, p. 269-286. In: N. Greenberg and P. D. MacLean. (eds.). *Behavior and neurology of lizards*. NIMH, Rockville, Md.
- KAUFMANN, J. H. 1983. On the definitions and functions of dominance and territoriality. *Biol. Rev.*, **58**:1-20.
- KREBS, J. R. AND R. H. MCCLEERY. 1984. Optimization in behavioral ecology, p. 91-121. In: J. R. Krebs and N. B. Davies (eds.). *Behavioral ecology: an evolutionary approach*. Blackwell Scientific Publications, London.
- KREKORIAN, C. O. 1976. Home range and overlap and their relationship to food abundance in the desert iguana *Dipsosaurus dorsalis*. *Herpetologica*, **32**:405-412.
- KWIAT, G. A. AND D. H. GIST. 1987. Annual reproductive cycle of an introduced population of European Wall Lizards (*Podarcis muralis*) in Ohio. *J. Herpetol.*, **21**:205-209.
- MILESTEAD, W. W. 1970. Late summer behavior of the lizards *Sceloporus merriami* and *Urosaurus ornatus* in the field. *Herpetologica*, **26**:341-357.
- ORIAN, G. H. 1961. The ecology of blackbird (*Agelaius*) social systems. *Ecol. Monog.*, **31**:285-312.
- OWEN-SMITH, N. 1977. On territoriality in ungulates and an evolutionary model. *Q. Rev. Biol.*, **52**: 16-31.
- PHILIBOSIAN, R. 1975. Territorial behavior and population regulation in the lizards, *Anolis acutus* and *A. cristatellus*. *Copeia.*, **1975**:428-444.

- RAND, A. S. 1965. The adaptive significance of territoriality in iguanid lizards, p. 106–115. In: W. W. Milestead (ed.). Lizard ecology: a symposium. Univ. Missouri Press, Kansas City.
- RODDA, G. H., B. C. BOCK, G. M. BURGHARDT AND A. S. RAND. 1988. Techniques for identifying individual lizards at a distance reveal influences of handling. *Copeia*, **1988**:905–913.
- ROSE, B. 1982. Lizard home ranges: methodology and functions. *J. Herpetol.*, **16**:253–269.
- RUBY, D. E. 1978. Seasonal changes in the territorial behavior of the iguanid lizard *Sceloporus jarrovi*. *Copeia*, **1978**:430–438.
- SAS INSTITUTE, INC. 1988a. SAS/STAT user's guide, release 6.03 ed. SAS Institute, Cary, North Carolina. 1028 p.
- . 1988b. SAS procedures guide, release 6.03 ed. SAS Institute, Cary, North Carolina. 441 p.
- SCHOENER, T. W. 1983. Simple models of optimal territory size: a reconciliation. *Am. Nat.*, **121**:608–629.
- . 1987. Time budgets and territory size: some simultaneous optimization models for energy maximizers. *Am. Zool.*, **27**:259–292.
- SIMON, C. A. 1975. The influence of food abundance on territory size in the iguanid lizard *Sceloporus jarrovi*. *Ecology*, **56**:993–998.
- AND G. A. MIDDENDORE. 1980. Spacing in juvenile lizards (*Sceloporus jarrovi*). *Copeia*, **1980**:141–146.
- SOKAL, R. R. AND F. J. ROHLF. 1981. Biometry, 2nd ed. W. H. Freeman and Co., New York. 859 p.
- STAMPS, J. W. 1977. Social behavior and spacing patterns in lizards, p. 237–311. In: C. Gans and D. W. Tinkle (eds.). Biology of the Reptilia, Vol. 7. Academic Press, Univ. of Michigan.
- . 1983. Sexual selection, sexual dimorphism, and territoriality, p. 169–204. In: R. Huey, D. Pianka and T. W. Schoener (eds.). Lizard ecology. Harvard Univ. Press, Cambridge, Mass.
- AND P. K. EASON. 1989. Relationships between spacing behavior and growth rates: a field study of lizard feeding territories. *Behav. Ecol. Sociobiol.*, **25**:99–107.
- STEWART, J. W. 1965. Territorial behavior in the wall lizard *Lacerta muralis*. *Br. J. Herpetol.*, **3**:224–229.
- STRIJBOSCH, H., J. J. BONNEMAYER AND P. J. M. DIETWORST. 1980. De muurhagedis (*Podarcis muralis*) in Maastricht (deel 1): Structuur en dynamiek van de populatie. *Natuurhist. Maandbl.*, **69**:210–217.
- TINKLE, D. W., S. MCGREGOR AND S. DANA. 1962. Home range ecology of *Uta stansburiana stejnegeri*. *Ecology*, **43**:223–229.
- . 1965. Home range, density, dynamics and structure of a Texas population of the lizard *Uta stansburiana*, p. 5–29. In: W. W. Milestead, (ed.). Lizard ecology. A symposium. Univ. Missouri Press, Kansas City.
- . 1967. The life and demography of the Side-blotched lizard, *Uta stansburiana*. *Mus. Comp. Zool. Univ. Mich.* 182 p.
- VIGLE, G. O. 1977. The history and distribution of an introduced population of *Lacerta muralis* in Cincinnati, Ohio. *Supp. Herpetol. Rev.*, **8**:19.
- WEBER, H. 1957. Vergleichende untersuchung des verhaltens von smaragdeidechsen (*Lacerta viridis*), mauereidechsen (*L. muralis*) und perleidechsen (*L. lepida*). *Z. F. Tierpsychol. Hamburg, Berlin*, **14**:448–472.
- WITTENBURGER, J. F. 1980. Group size and polygamy in small mammals. *Am. Nat.*, **115**:197–222.